

INSTALLATION INSTRUCTIONS: POLARIS RZR TURBO R MOJAVE SLIP-ON EXHAUST PART# 11015

Congratulations, you have purchased the finest exhaust available for your SXS. Your Vance & Hines exhaust is designed and crafted for performance, quality and style. Please follow the instructions below, check exhaust system for missing or damaged parts and if you need any assistance please contact our technical support line (562) 921-7461.

FITMENT: 20-23 RZR PRO XP MODELS
22-23 RZR TURBO R MODELS

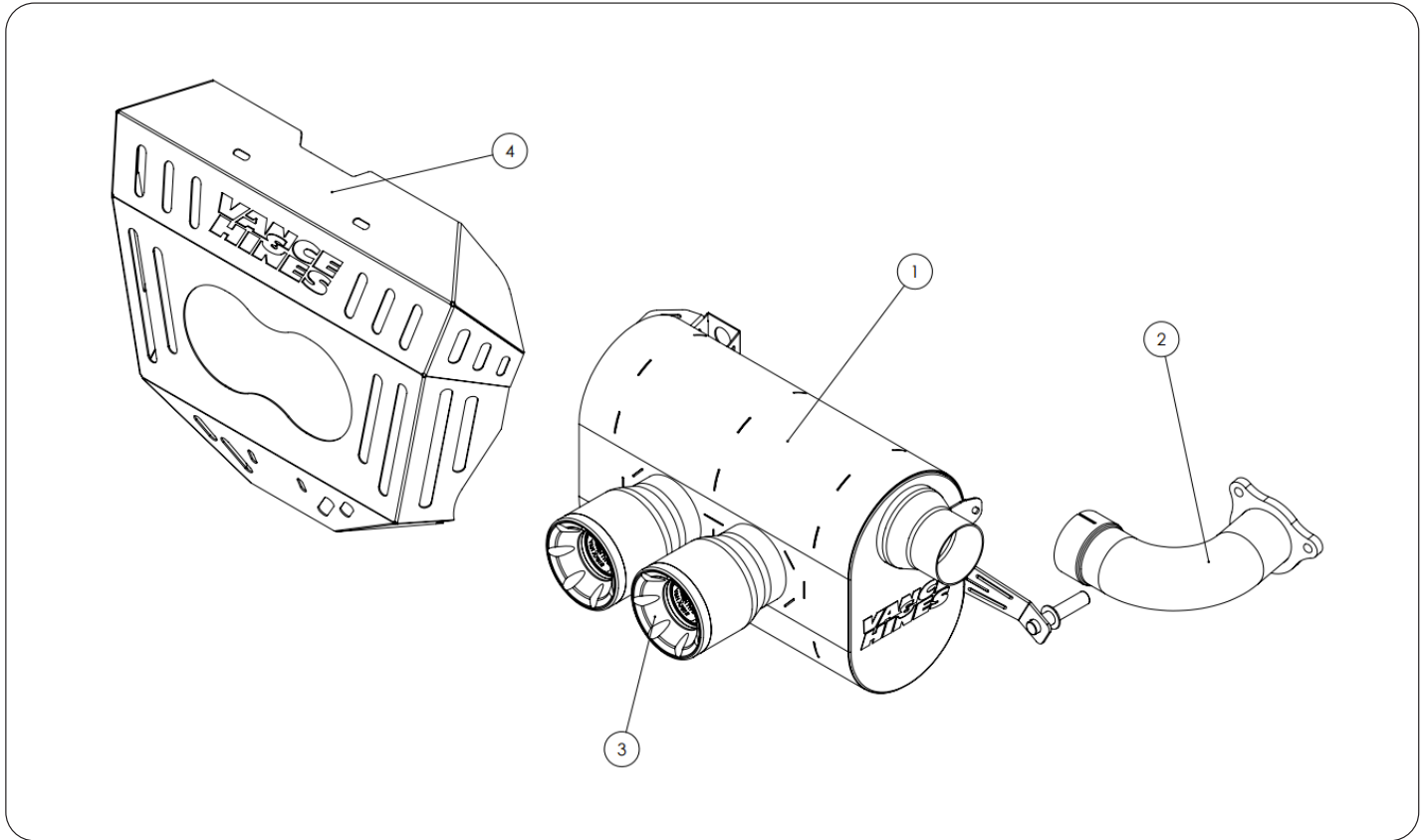

PARTS LIST

NO.	DESCRIPTION	QTY	NO.	DESCRIPTION	QTY.
1	MUFFLER ASSEMBLY	1	10	EXHAUST CLAMP	1
2	MIDPIPE	1	11	53mm EXHAUST SPRING	1
3	MUFFLER OUTLET	2	12	SPRING PULLER	1
4	REAR COVER	1	13	SNAP IN NUT (.064-.105)	2
5	76MM EXHAUST SPRING	1	14	1/4 IN BLACK WASHER SS	4
6	TOP V&H COVER BRACKET	2	15	1/4-20 X 3/4 BHCS	4
7	LOWER V&H COVER BRACKET	1	16	SNAP IN NUT (.093-128)	2
8	RS REAR COVER BRACKET	1	17	RUBBER GROMMET	1
9	LS REAR COVER BRACKET	1			

HARDWARE

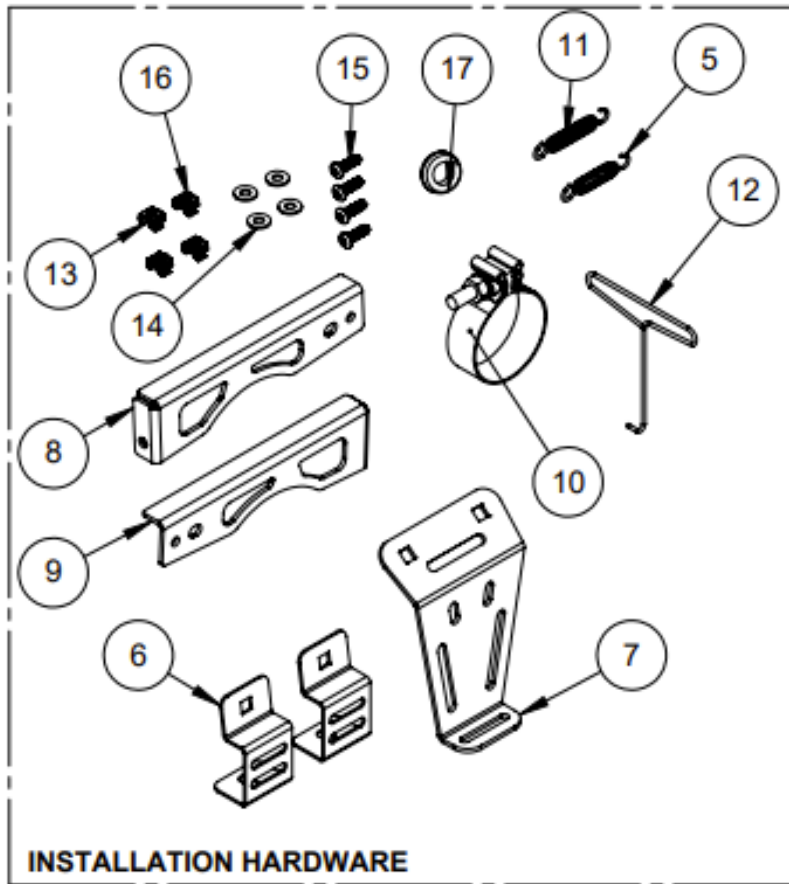

TOOLS REQUIRED

 Flat Blade Screwdriver
Soft Blow Rubber Mallet

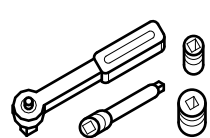
 1/4" or 3/8" Drive Ratchet
6" extension
10mm and 13mm socket
T40 Torx socket
5/32" Allen Socket
5/8" 6-point socket

 Allen Wrenches: 5/32"
Torx Wrench: T30

 Foot-Pound Torque
Wrench

OEM SYSTEM REMOVAL

1. Loosen and remove OEM rear cover. See **FIG 1**. Rear cover will not be reinstalled.
2. Loosen and remove OEM muffler heat shield to gain access to muffler mounting springs. See **FIG 2**.
3. Loosen and remove exhaust flange nuts. Set aside for installation. Remove OEM muffler, rear cover mounting brackets and hardware from vehicle. See **FIG 2-4**.

STEP 1: Remove left and right rear cover mounting brackets. Brackets will not be reinstalled.

STEP 2: Remove OEM muffler from vehicle and set aside.

STEP 3: Remove upper and lower cover mounting hardware and set aside.

V&H EXHAUST INSTALLATION

1. For a clear understanding of this installation, it is best to refer to the exploded view diagram while reading these instructions. Install exhaust spring (#5) into upper left frame hole only. See **FIG 4**. Install rubber grommet (#17) into LS spring bracket. See **FIG 5**. Spray lubricant (water or windex) into bottom rubber mounts and install muffler on vehicle. Use spring puller (#11) to attach left side exhaust spring. See **FIG 5**.
2. Install midpipe (#2) onto OEM header and loosely tighten hardware. Slide exhaust clamp (#10) onto midpipe and spray lubricant onto muffler inlet. Install midpipe and carefully tap into place as needed with rubber mallet. Make sure midpipe slot completely covers inlet. Carefully install right side exhaust spring to hold muffler assembly tight against vehicle frame. See **FIG 6**. Reuse OEM hardware to install rear cover brackets (#8 and #9).
3. Install snap-in nut (#13) into top bracket (#6) and snap-in nut (#16) into bottom bracket (#7). Use OEM hardware and install upper mounting bracket (#6) make sure bracket is straight and parallel to muffler body face. Install lower mounting bracket (#7) using OEM hardware and tighten. See **FIG 7**. Wipe down muffler body to remove any fingerprints, oil or residue from installation process.
4. Attach rear cover (#4) to mounting brackets (#6 and #7) with hardware (#12 and #14) hand tighten only. Adjust cover as needed to muffler tips, when satisfied with fit, tighten. Adjust upper brackets as needed. TIP: PLACE A SOFT MICROFIBER TOWEL ON MUFFLER TIPS TO PROTECT FROM SCRATCHING DURING COVER INSTALL. See **FIG 8**.
5. Torque exhaust clamp to 42 lbs-ft and check vehicle for any exhaust leaks or rattles. Tighten as needed.

FIG 1: OEM COVER BOLT LOCATION

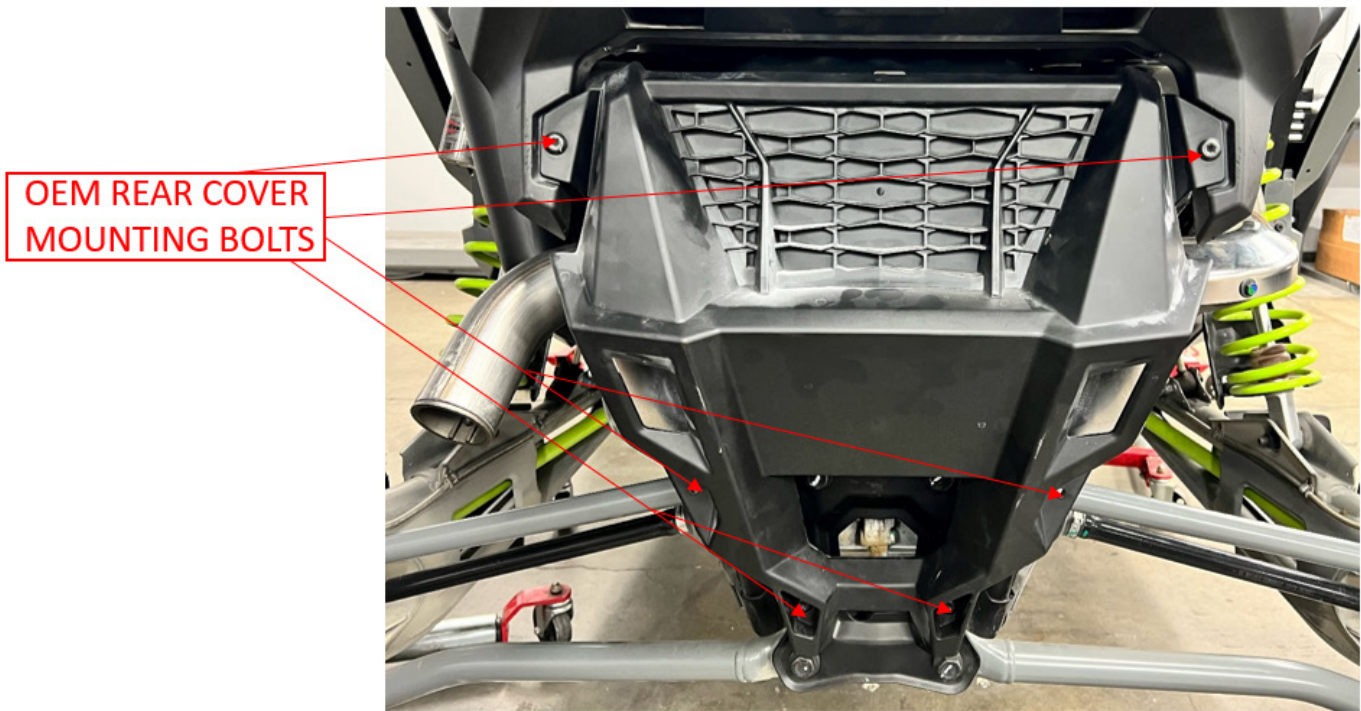

FIG 2: OEM HEAT SHIELD AND SPRING LOCATION

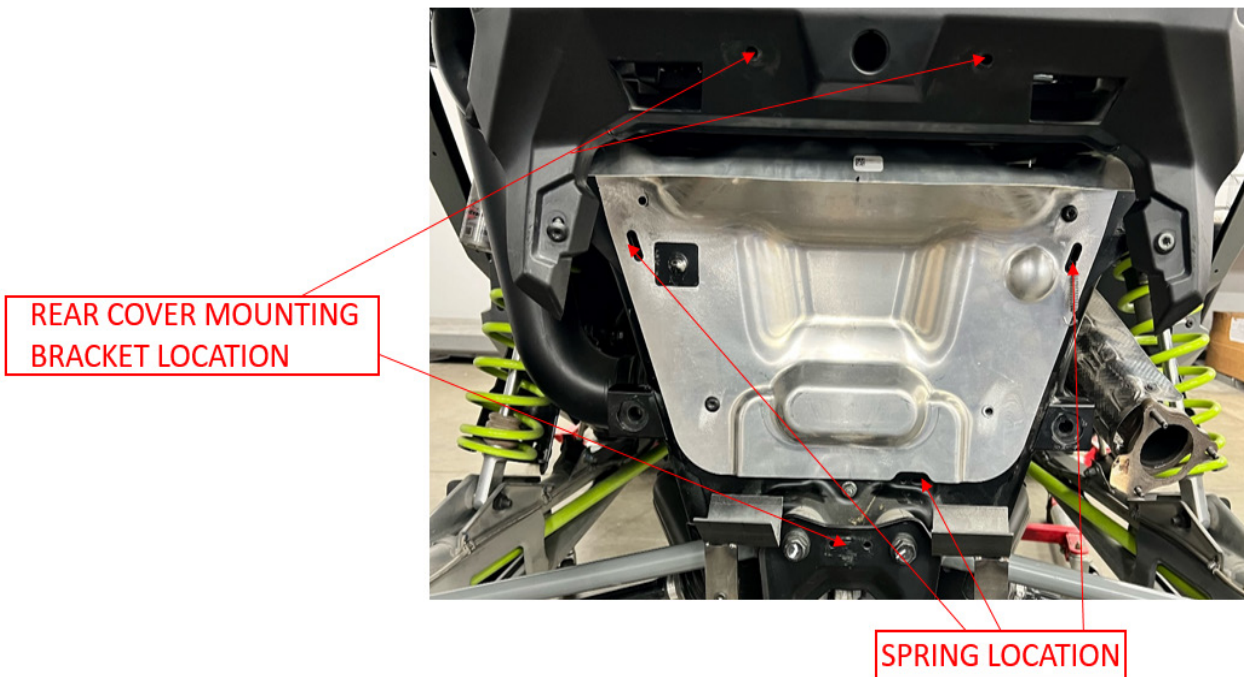

FIG 3: OEM COVER BRACKET



OEM REAR COVER BRACKETS

FIG 4: SPRING AND REAR COVER LOCATION



REAR COVER MOUNTING BRACKET LOCATION

SPRING LOCATION

FIG 5: V&H EXHAUST SPRING MOUNT LOCATION

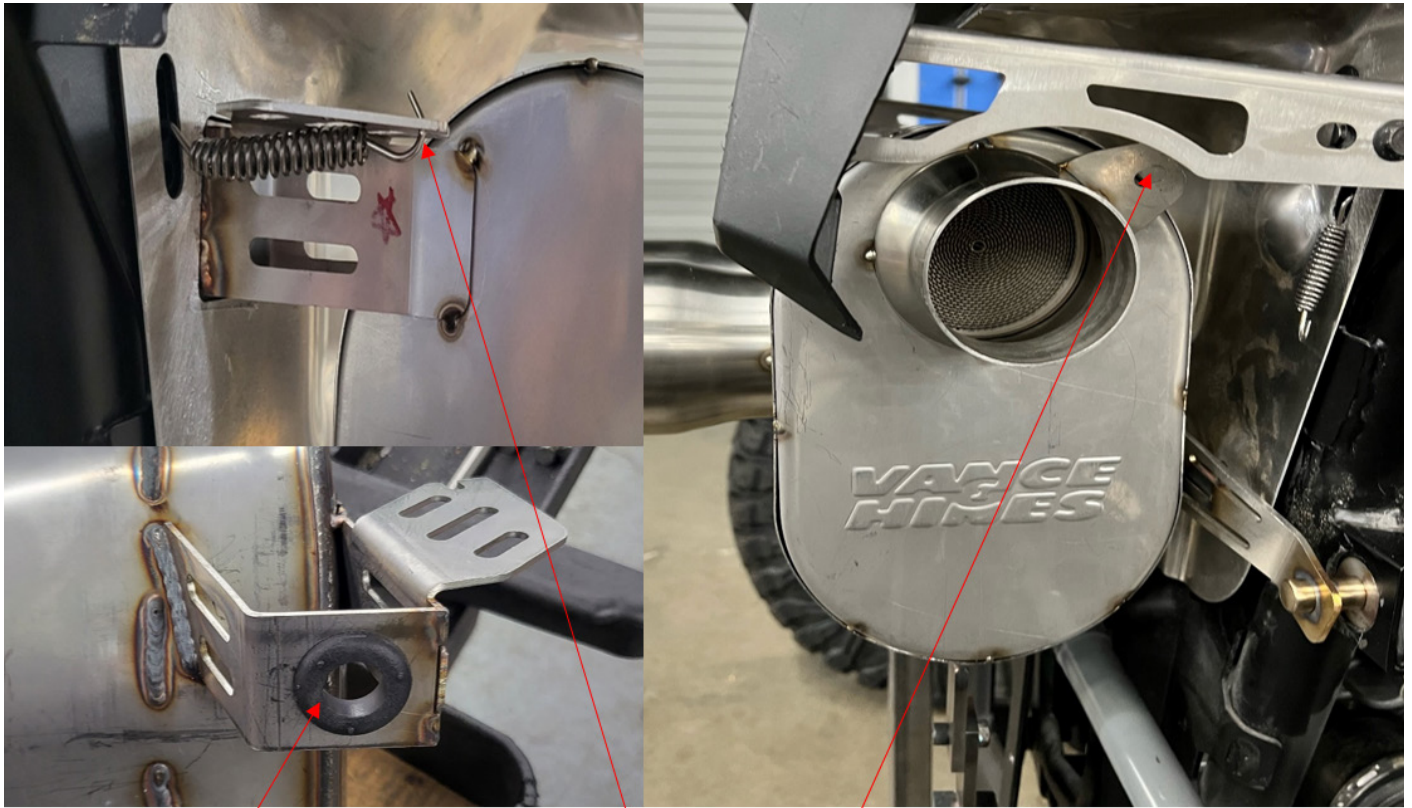

ITEM #17

V&H SPRING TAB LOCATION

FIG 6: V&H MIDPIPE AND CLAMP



EXHAUST CLAMP

FIG 7: REAR COVER MOUNTING BRACKETS

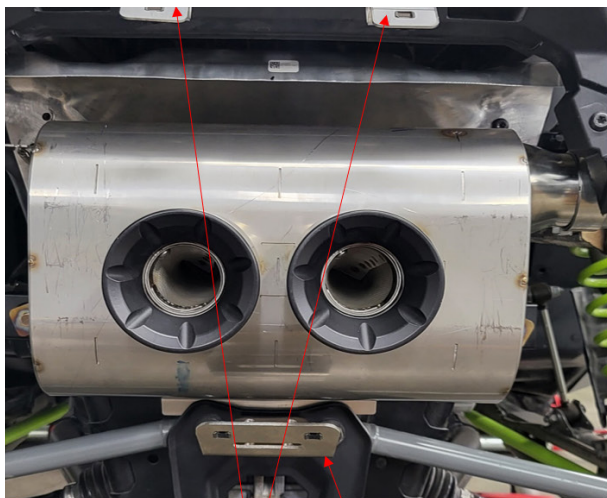

V&H REAR COVER MOUNTING BRACKETS

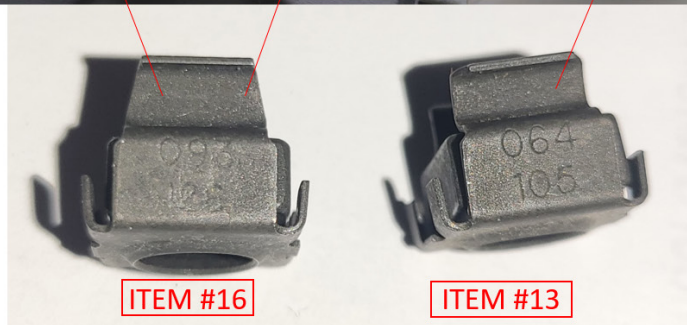
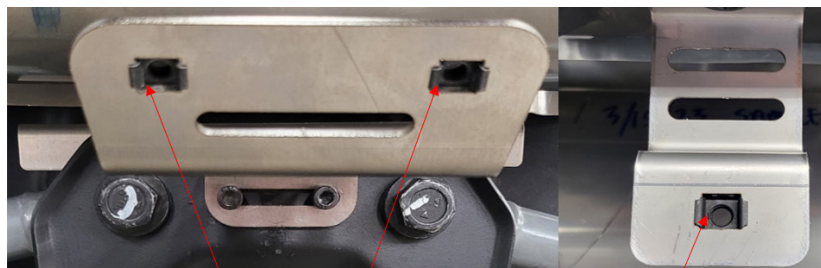

ITEM #16

ITEM #13

FIG 8: REAR COVER ALIGNMENT

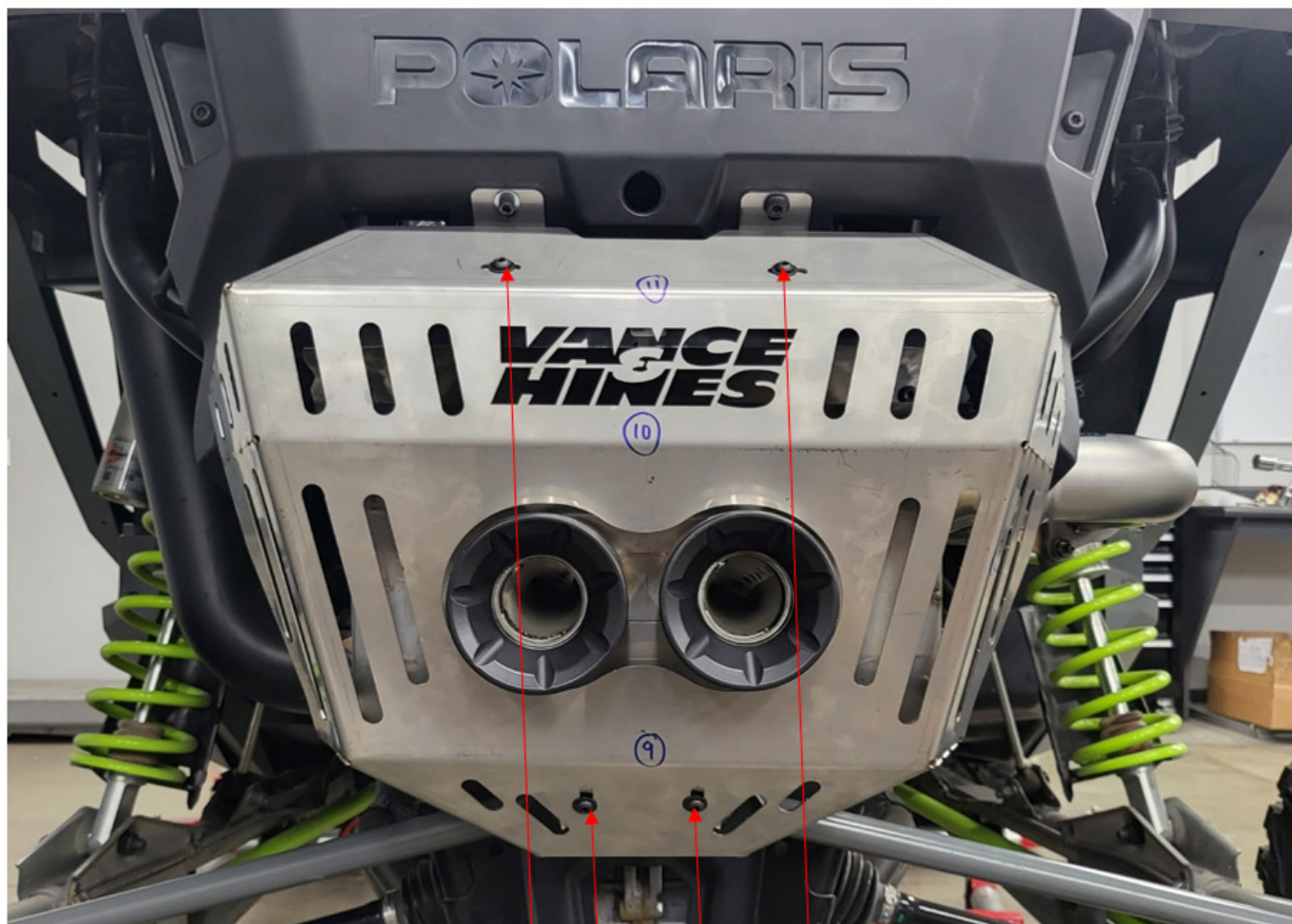

V&H REAR COVER MOUNTING POINTS

Emissions Notice:

In California, in order to meet Air Resources Board emissions requirements, certain aftermarket part applications have been identified as replacements, and others have received ARB Executive Orders. All other emissions related aftermarket parts are for competition use only. A list of replacement parts and EO parts, and corresponding [fitment](http://vanceandhines.com/California) is provided at vanceandhines.com/California.

Warranty:

All Vance & Hines products are warranted against defects in material and workmanship for a period of 90 days. This warranty does not cover discoloration or rust. This warranty shall be limited to the repair or replacement of the product, which may be proven defective under normal use. Vance & Hines will not warranty any system that has been abused, misused, improperly installed or modified.

Dealers or distributors are not authorized to make dispositions binding upon Vance & Hines. Vance & Hines will not be responsible for any labor charges incurred in removing or replacing any system under warranty. A return authorization number and a copy of the original purchase invoice must accompany all returns. Parts returned without a return authorization may be refused.]