

Congratulations, you have purchased the finest exhaust system available for your motorcycle. Your Vance & Hines exhaust is designed and crafted for performance, quality, and style. Please follow the instructions below, check exhaust system for missing or damaged parts and if you need any assistance please contact our technical support line (562) 921-7461.

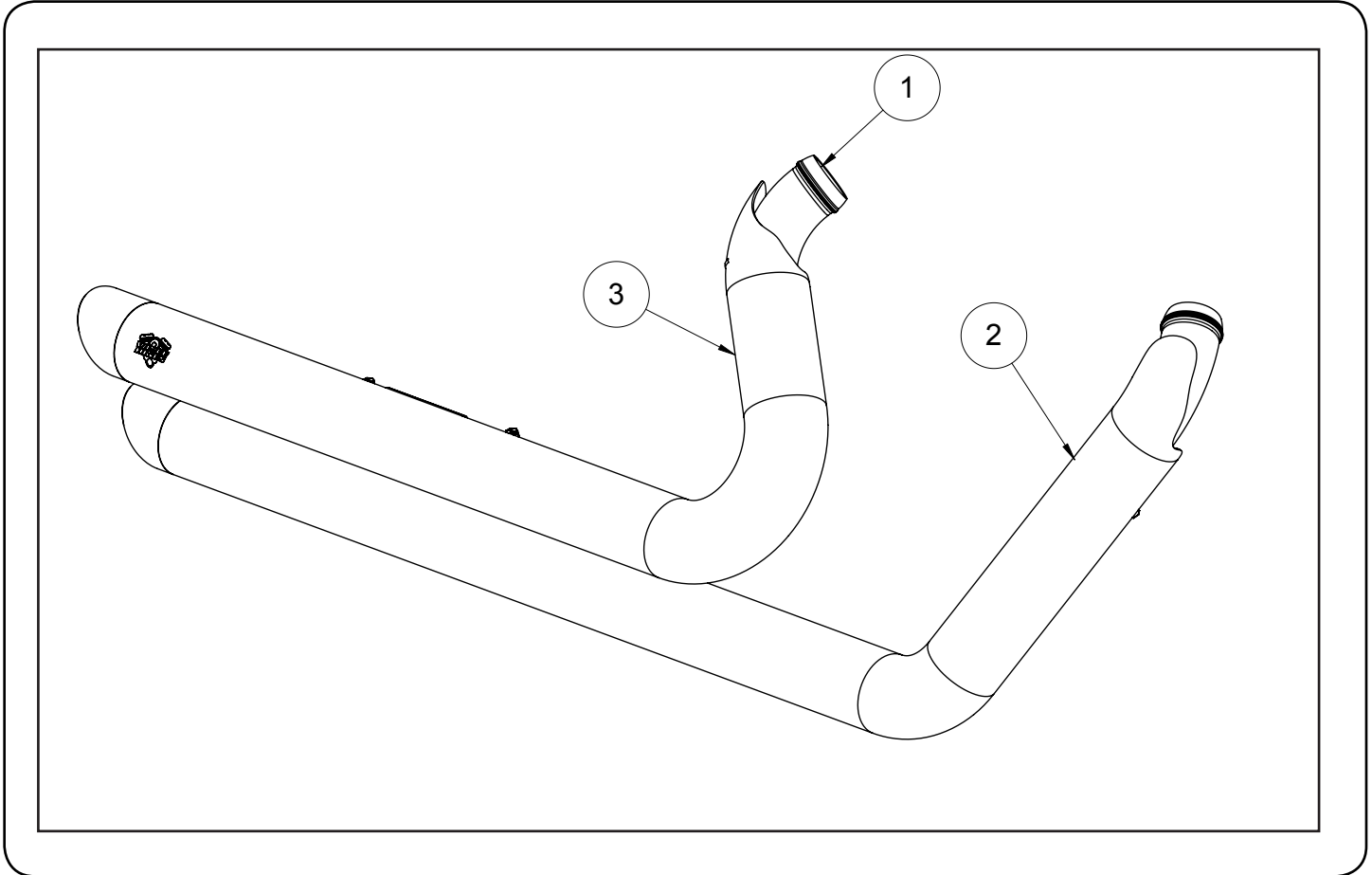

PARTS LIST

NO.	PART NO.	Description	Qty.
1	D1125FC	Header Assembly	1
2	D1124HC/D1324HP	Front Heat Shield	1
3	D1125HC/D1325HP	Rear Heat Shield	1
4	A644ST	O2 Adaptor	2
5	A740ST-P	Controls Spacer	2
6	A745HW-P	Lever Spacer	1
7	A739HW	5/16-24x 1.25BHCS	1
8	A826HW	3/8-16 x 2.25 SHCS	2
9	A260HW	3/8-16 x 1 Hex Bolt	2
10	A240HW	5/16-18 x 5/8 FHS	4
11	A270HW	No. 20 Hose Clamp	3
12	A272HW	No. 28 Hose Clamp	4
13	A195HW	Nut Plate	2
14	1103-P	Bracket Spacer	1
15	1143-P	Mount Bracket	1

HARDWARE

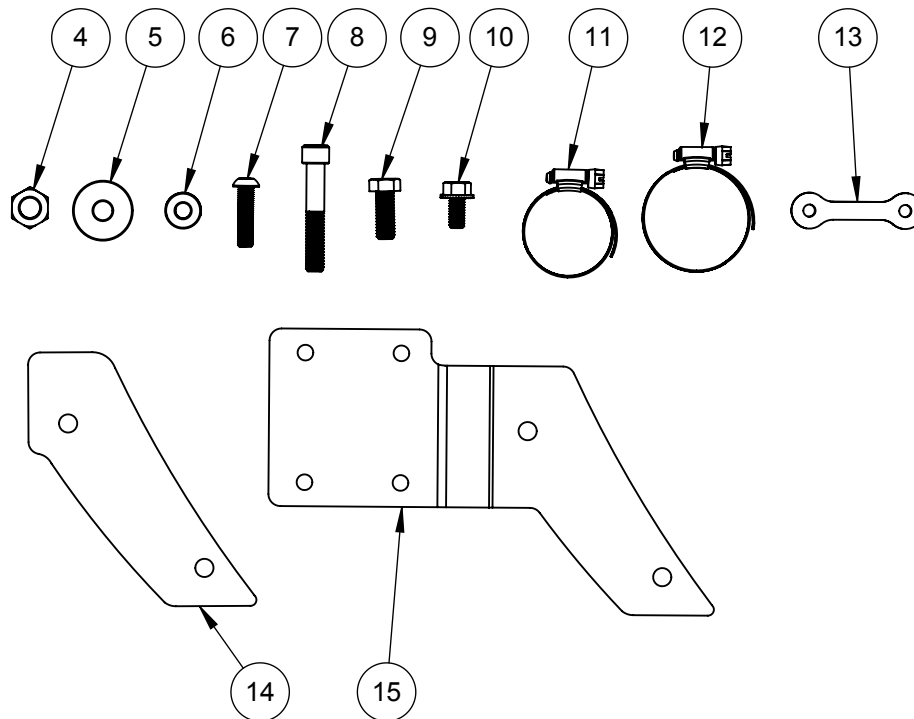

TOOLS REQUIRED

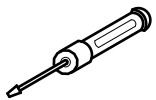

Flat Head Screwdriver

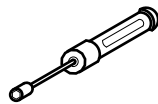

5/16 Nut Driver

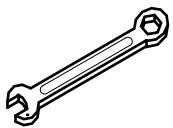

Combination Wrench:
1/2" & 14mm

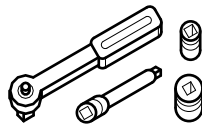

3/8" Drive Ratchet w/ 4" extension
1/2" & 3/4" Socket,
1/2" Deep Socket
5/32", 3/16", 5/16" Allen Sockets

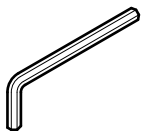

Allen Wrenches: 3/16",
5/16"

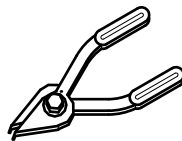

Snap Ring Pliers

STOCK EXHAUST SYSTEM REMOVAL

- 1.** Locate the rear O2 sensor connector. Remove the two bolts holding the right side cover in place and gently pull cover off bike. NOTE: Pay attention to the wire routing for re-installation.
- 2.** Locate the front O2 sensor connector. Unplug the sensor and feed the end of the wire through the frame, freeing it from the motorcycle.
- 3.** On Floor board models, loosen the right-hand floor board mounting bolts to gain clearance for the exhaust removal and installation.
- 4.** On Mid Mount models remove the forward brake rod bolt and remove the mid mount foot peg bracket.
- 5.** Loosen the heat shield clamps on both the front and rear exhaust pipes.
- 6.** Remove the two mounting nuts from each head pipe, located at the cylinder head.
- 7.** Remove the bolts attaching the mufflers to the mounting bracket.
- 8.** Remove the entire exhaust system and set it aside.
- 9.** Remove the stock mounting bracket.
- 10.** Carefully remove the exhaust port flanges and circlips from the stock exhaust system using the snap ring pliers. NOTE: Replace bent or damaged circlips.
- 11.** Carefully remove the O2 sensors from the stock head pipes and save for re-use with the new system.
- 12.** Check the condition of the exhaust gasket and replace if worn or damaged. Harley Davidson part number 65324-83B.

VANCE & HINES EXHAUST INSTALLATION

1. Install the supplied mounting bracket, 1143-P. Using the supplied hardware 3/8-16 x 1" Hex bolt. Place the bracket spacer 1103-P in-between the frame and the 1143-P bracket. Torque the mounting bracket bolts to 30-33 Ft./Lbs.
2. Remove head pipes from their protective packaging and install circlips and flanges from the stock system onto both new head pipes.
3. Apply a small amount of anti-seize compound to the threads of the O2 sensors and install them into the new head pipe. Install supplied 18mm to 12mm oxygen sensor adapter then install 12mm oxygen sensors.
4. Remove heat shields from their protective packaging. Note: Removal of the end cap may be required. Place each heat shield on a non-abrasive surface such as a blanket or carpet. For chrome, use a felt tip pen and for black systems, use a pencil. Lightly mark the outside edge of each heat shield to show location of mounting clips where hose clamps will loop through. NOTE: Pencil marks can be erased if care is taken not to harm coating.
5. Lay headers into the heat shields tail end first.
6. Install the end caps (if removal was necessary) into the tail end of each heat shield engaging head pipe and heat shield. Align mounting hole with the end cap hole. Install and tight 1/4-20 button head screws. Note: Removable thread locking compound is recommended.
7. Loosely install hose clamps by feeding the tail end of the clamp into the heat shields clips. Use #20 hose clamps for head pipes areas and #28 hose clamps for muffler areas. Take note of the screw direction. Figure 1. Screw head should be accessible when system is installed on motorcycle for adjustment purposes. Note Do not tighten at this time.
8. Using stock flange nuts, carefully install the head pipes into exhaust ports. Do not tighten the nuts at this time.
9. Attach the mufflers to the mounting bracket. Using the two supplied nut plates and 5/16-18 flange bolts. Slide the nut plates inside the brackets that are welded to the backside of each muffler.
10. Make sure to align the head pipes and heatshields then tighten the cylinder port exhaust flange nuts on front and rear cylinders. See **Figure 2**.
11. On floor board models, re-install and tighten the floor board mounting bolts.
12. On mid mount models re-install mid mount foot peg bracket with spacers and new hardware.
13. Re-install forward brake rod with spacer between brake rod and brake pedal support.
14. For models with passenger foot peg attached to the stock exhaust bracket, remove the upper plug on the frame and re-install the left and right side passenger foot pegs into the upper mounting holes. Figure 5.
15. Tighten the hose clamp heat shields.
16. Route the O2 sensor and reconnect O2 sensors to the wire harness.
17. Be sure to tighten all hardware before starting the motorcycle.

FIGURE 1

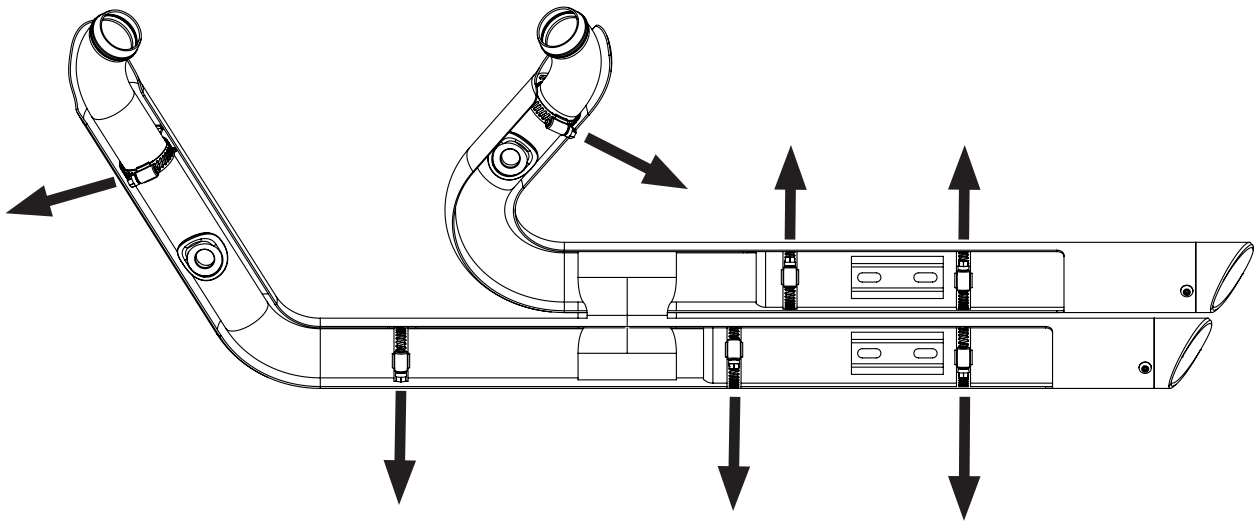

FIGURE 2



EXHAUST CARE

1. When installing a new set of chrome pipes, make sure your hands are clean and free of oil. After installation, thoroughly clean pipes with a soft cloth and cleaning solvent that will leave no residue before starting the motorcycle.
2. Avoid long periods of idling as this can cause discoloration.
3. Intake leaks can cause the engine to run lean and overheat, this could lead to discoloration.
4. Make sure there are no exhaust leaks at the junction of the exhaust pipes and cylinder head. We recommend replacing gaskets if they are worn.

EXHAUST CARE (BLACK)

1. When installing a new set of black pipes, make sure your hands are clean and free of oil. After installation, thoroughly clean pipes with a warm soapy water and a soft cloth. Dry with a clean towel to remove any residue before starting the motorcycle. Do NOT use anything abrasive to clean the pipes.
2. Avoid long periods of idling as this can cause discoloration.
3. Intake leaks can cause the engine to run lean and overheat, this could lead to discoloration.
4. Make sure there are no exhaust leaks at the junction of the exhaust pipes and cylinder head. We recommend replacing gaskets if they are worn.

Emissions Notice:

In California, in order to meet Air Resources Board emissions requirements, certain aftermarket part applications have been identified as replacements, and others have received ARB Executive Orders. All other emissions related aftermarket parts are for competition use only. A list of replacement parts and EO parts, and corresponding fitment is provided at vanceandhines.com/California.

Warranty:

All Vance & Hines products are warranted against defects in material and workmanship for a period of 90 days. This warranty does not cover discoloration or rust. This warranty shall be limited to the repair or replacement of the product, which may be proven defective under normal use. Vance & Hines will not warranty any system that has been abused, misused, improperly installed or modified.

Dealers or distributors are not authorized to make dispositions binding upon Vance & Hines. Vance & Hines will not be responsible for any labor charges incurred in removing or replacing any system under warranty. A return authorization number and a copy of the original purchase invoice must accompany all returns. Parts returned without a return authorization may be refused.

13861 ROSECRANS AVENUE / SANTA FE SPRINGS, CA 90670
SALES: (562) 921-5388
TECHNICAL: (562) 926-5291
FAX: (562) 802-0110

vanceandhines
.com