



INDIAN CHIEF VINTAGE CLASSIC INSTALLATION INSTRUCTIONS PART# 18537

Congratulations, you have purchased the finest exhaust system available for your motorcycle. Your Vance & Hines exhaust is designed and crafted for performance, quality, and style. Please follow the instructions below, check exhaust system for missing or damaged parts and if you need any assistance please contact our technical support line (562) 921-7461.

PARTS LIST

ITEM NO.	PART NO.	DESCRIPTION	QTY.
1	I310RC	RIGHT SIDE MUFFLER	1
2	I315RC	LEFT SIDE MUFFLER	1
3	A335HW	TORCA CLAMP	2
4	A240HW	5/16-18 FLANGE BOLT	4

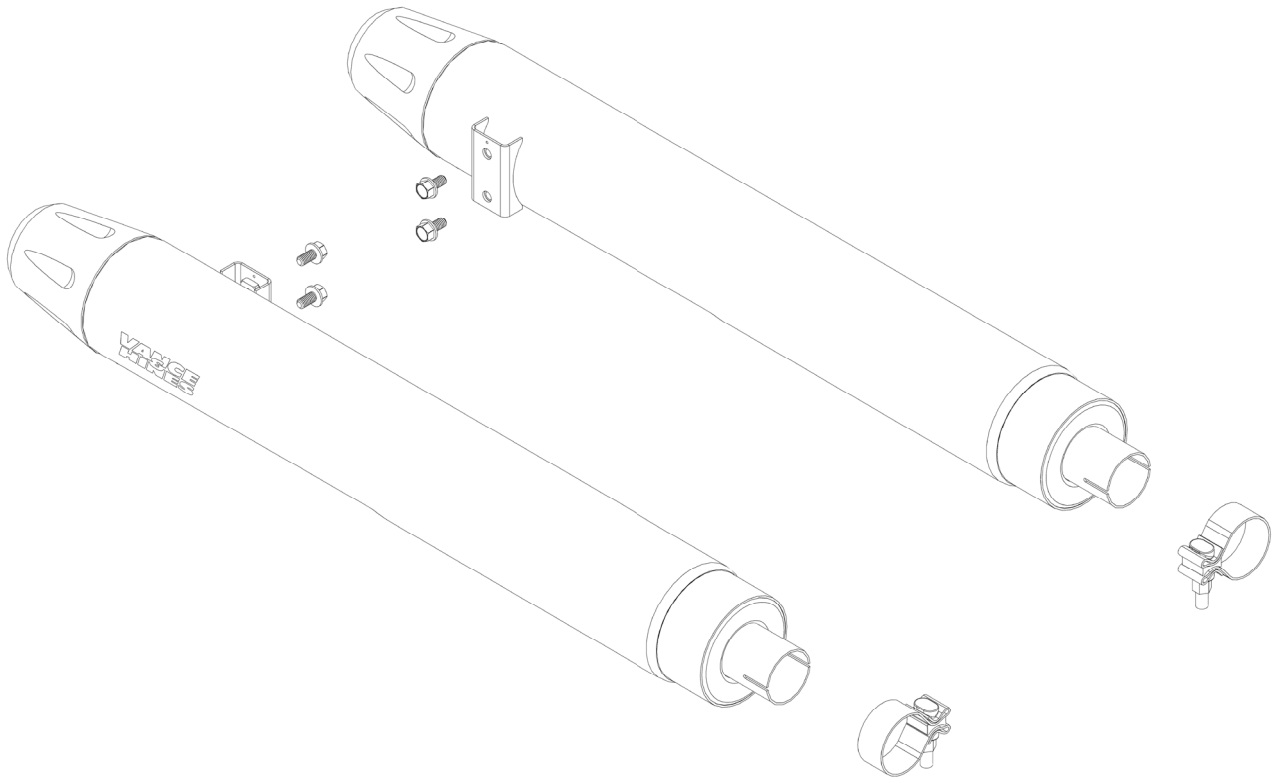

TOOLS REQUIRED

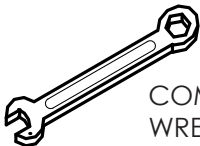

COMBINATION
WRENCH: 9/16", 13mm

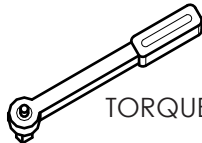

TORQUE WRENCH: In./Lbs.

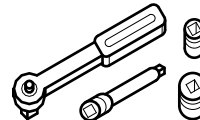

3/8" RATCHET
SOCKETS:
9/16", 13mm, 1/2"

STOCK EXHAUST SYSTEM REMOVAL

1. On both sides, loosen both Torca band clamp and hose clamp on the front end of each mufflers.
2. Using 13mm wrench remove two M8 x 1.25mm bolts that mount the muffler to the bike and slide muffler off of head pipe.

VANCE & HINES EXHAUST INSTALLATION

1. Install the Torca band clamp (supplied) over the front of each muffler so that the bolt is to the inside and the nut is facing down. NOTE: Do not use old Torca clamps.
2. Slip the muffler over the stock head pipe and mount the muffler to the support bracket using two 5/16-18 flange bolts (supplied) and tighten. NOTE: There are different mufflers, logo faces outwards.
3. Tighten the two muffler Torca band clamps. (Torque specification 40-45 ft/lbs.)
4. Be sure to tighten all hardware before starting your motorcycle.
5. After test ride let pipes cool down and re-torque muffler band clamps.

EXHAUST CARE

1. When installing a new set of chrome pipes, make sure your hands are clean and free of oil. After installation, thoroughly clean pipes with a soft cloth and cleaning solvent that will leave no residue (chrome wax/polish, glass cleaner, alcohol, ammonia, etc...) before starting the motorcycle.
2. Avoid long periods of idling as this can cause discoloration.
3. Intake leaks can cause the engine to run lean and overheat, this could lead to discoloration.

Emissions Notice:

In California, in order to meet Air Resources Board emissions requirements, certain aftermarket part applications have been identified as replacements, and others have received ARB Executive Orders. All other emissions related aftermarket parts are for competition use only. A list of replacement parts and EO parts, and corresponding fitment is provided at vanceandhines.com/california.

Warranty:

All Vance & Hines products are warranted against defects in material and workmanship for a period of 90 days. This warranty does not cover discoloration or rust. This warranty shall be limited to the repair or replacement of the product, which may be proven defective under normal use. Vance & Hines will not warranty any system that has been abused, misused, improperly installed or modified.

Dealers or distributors are not authorized to make dispositions binding upon Vance & Hines. Vance & Hines will not be responsible for any labor charges incurred in removing or replacing any system under warranty. A return authorization number and a copy of the original purchase invoice must accompany all returns. Parts returned without a return authorization may be refused.

13861 ROSECRANS AVENUE / SANTA FE SPRINGS, CA 90670
SALES: (562) 921-5388
TECHNICAL: (562) 926-5291
FAX: (562) 802-0110

vanceandhines
.com